

Production know-how

- ▶ Mix preparation
- ▶ Continuous freezing
- ▶ Low temperature freezing
- ▶ Ingredient dosing
- ▶ Filling
- ▶ Moulding
- ▶ Extrusion
- ▶ Wrapping
- ▶ Consumables



Ice cream solutions from Tetra Pak

Raw material tanks
Tetra Hoyer Promix plant
Ageing tanks

Tetra Hoyer DeepBlue CK Low temperature freezers
Tetra Hoyer Comet filling machines



Tetra Hoyer Frigus SF self contained freezers
Tetra Hoyer Frigus KF continuous freezers
Tetra Hoyer Addus FF fruit feeders

Tetra Hoyer Rollo RM moulding machines
Tetra Hoyer Flowrap MW wrapping machines
Tetra Hoyer Straightline C/F extrusion machines
Tetra Hoyer Dino transfer system

BUIC Technical Sales & Service Support



Mix preparation

Tetra Hoyer Promix C

- ▶ Full capacity range for all ice cream mix types
- ▶ Automation solutions from manual to full traceability
- ▶ Highest levels of hygiene and production efficiency



Self-contained freezing

Tetra Hoyer Frigus SF

- ▶ Compact design requiring less floor space
- ▶ Simple, sturdy controls secure easy operation
- ▶ Hermetic scroll compressor, noiseless and maintenance-free



Continuous freezing

Tetra Hoyer Frigus KF

- ▶ Faster start-up
- ▶ Compensation for atmospheric pressure changes
- ▶ Standard deviation



Low temperature freezing

Tetra Hoyer DeepBlue CK

- ▶ Ice cream at -12 to -15°C (10 to 5°F)
- ▶ Superior sensory and shaping properties
- ▶ Reduced ingredient costs
- ▶ Excellent mouth feel and creamier ice cream even with lower fat content



Ingredient dosing

Tetra Hoyer Addus FF

- ▶ Unique lamella pump design to secure stable performance
- ▶ Compact, ergonomic design for easy and flexible operation
- ▶ Superior dosing accuracy of ingredients
- ▶ Gentle handling of brittle and sticky ingredients

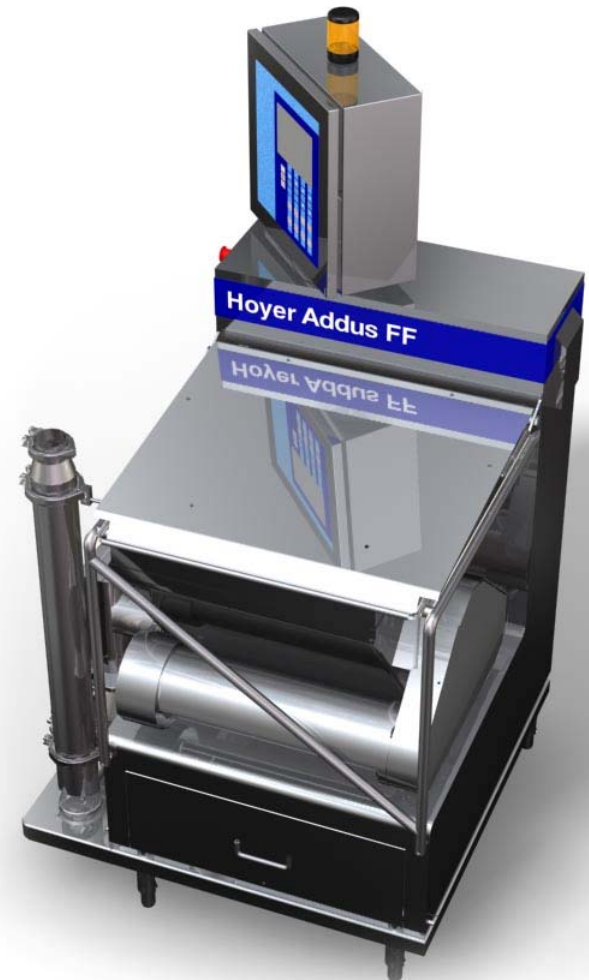

Wrapping machine

Tetra Hoyer Flowrap MW

- ▶ Multi-lane wrapping in 3-12 lanes
- ▶ Capacity up to over 40,000 products/hour
- ▶ Hygienic design
- ▶ Easy feeding of new paper
- ▶ Easy access to paper rolls

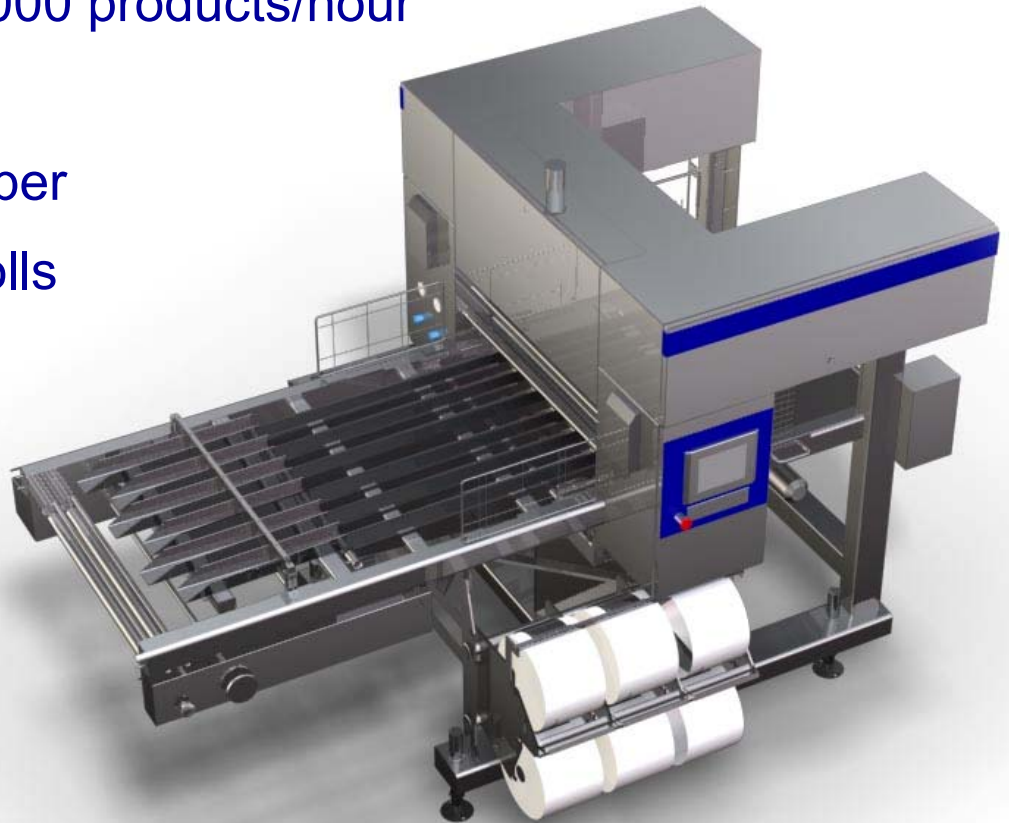

Moulded stick novelty lines

Tetra Hoyer Rollo RM

- ▶ Capacities: Up to 36.000 sticks per/hour
- ▶ Water ice sticks / Ice cream sticks
- ▶ Focus on hygiene
- ▶ Superior mould freezers and upgrade kits
- ▶ Economic operation

Add-on: Tetra Hoyer Profill F1
to create new, exciting products

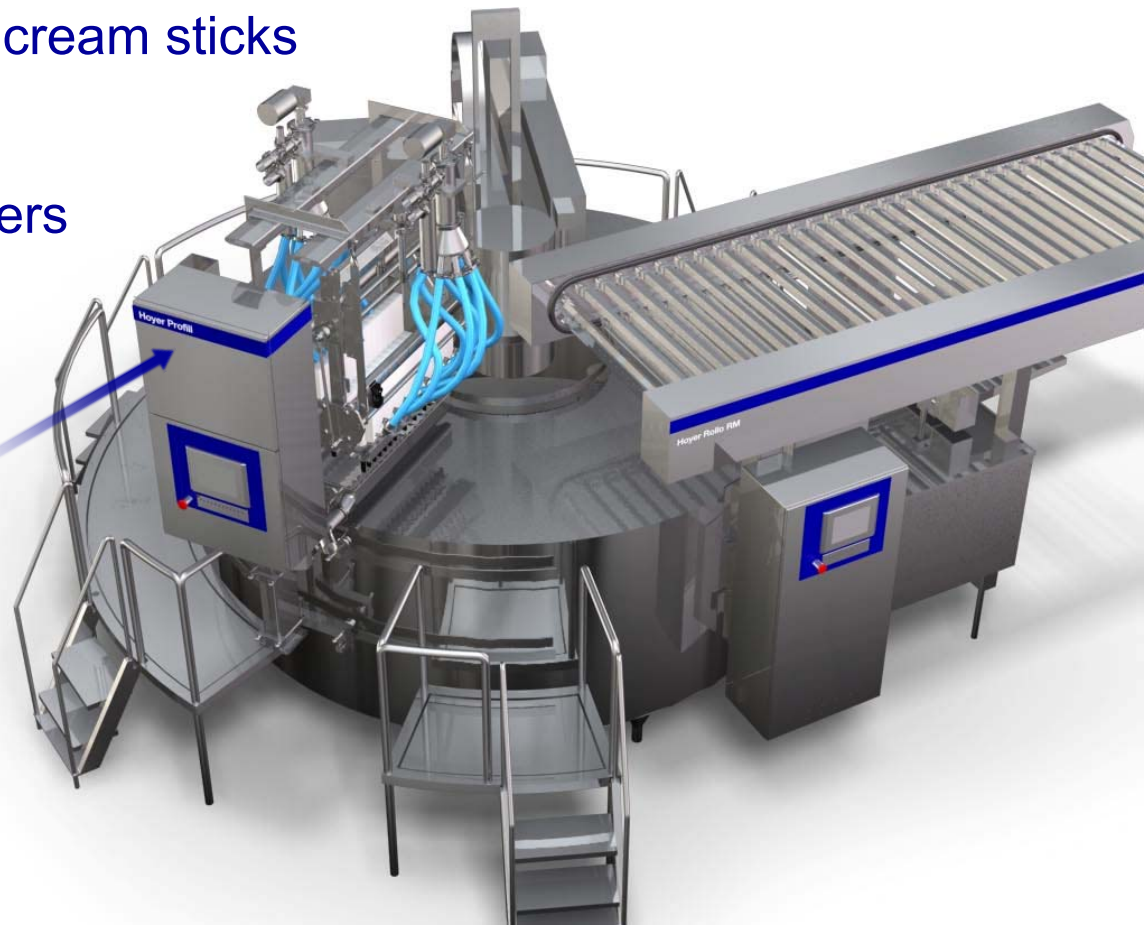

Filled product lines

Tetra Hoyer Comet C2

- ▶ Capacities: Up to 12.000 products per/hour
- ▶ Focus on hygiene
- ▶ Interchangeable dispensing, filling and decoration
- ▶ Accurate filling increases profit

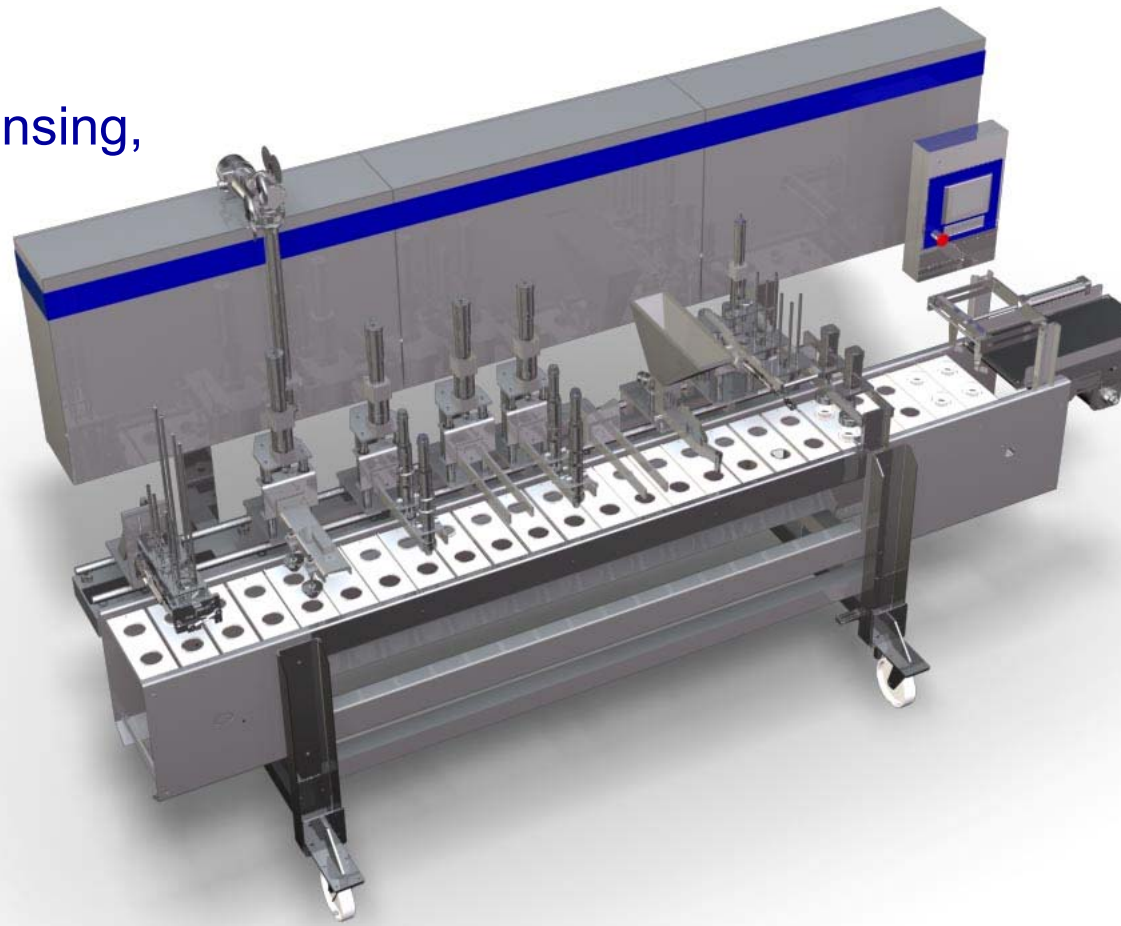

Extruded product lines

Tetra Hoyer Straightline C/F2

- ▶ Capacities: Up to 36.000 products per/hour
- ▶ Unique system design
- ▶ Efficient product transfer
- ▶ Various product shapes and sizes



Total ice cream solutions

from Tetra Pak

