

# Tetra Brik® Tetra Brik® Aseptic

♥ smartness





# Tetra Brik<sup>®</sup> ♥ smartness



In 2004, the Tetra Brik package was exhibited as a Humble Masterpiece at the Museum of Modern Art in New York. The exhibition showed “everyday inspired designs that help make life easier, safer and more fulfilling”.

A Tetra Brik package is one of those great ideas that baffles you with its simplicity. It's an evolving phenomenon, creating value for the brand on the outside of the package, whilst protecting the product inside. Its design makes it one of the most efficient carriers of beverages. No unnecessary material, weight or space, just a simple and ingenious brick-shaped carton. In a way, it's the closest thing to not having a package at all.

The pure, lean logistics of Tetra Brik packaging, along with great possibilities for creative marketing and branding solutions, make great sense to marketing, production, sales and finance managers all over the world.

How can an innovation from the '60s still be important today? Because it's smart. And that's why we continue to invest in development.

Not glorious. Just smart. We love it...





The **Myran chair**, brought to us by Arne Jacobsen in 1952, is a design classic combining good aesthetics with great functionality (it's stackable!). Like Tetra Brik packages, it proves that truly great ideas and ingenious shapes don't go out of style.



## EVERYDAY SMART.

A Tetra Brik package protects what's good inside, is shatterproof, transports & carries easily and requires a minimum of space at home. It's good and it's there. Everywhere.



Tetra Brik® is the best selling brand of carton packages for liquid beverages, ever. Tetra Brik and Tetra Brik Aseptic packages have been an ongoing innovation for decades and are still challenging the liquid food industry, with fresh thinking and ideas to match the requirements of today (and tomorrow). Offering what's needed, no more no less.

A photograph of a snowy landscape at dusk or dawn. In the foreground, a wooden sled with a curved handle is positioned on the snow. In the background, a large, illuminated igloo stands on the snow. The sky is a mix of blue and purple, suggesting twilight. The overall scene is serene and cold.

# SMART EVERYWHERE.

North or South. Hot or Cold.  
Fridge or no Fridge. We have a Solution.

## CHILLED SOLUTIONS

The Tetra Brik package was originally developed for the chilled distribution of milk. Since then, it has continued to be a successful solution in tune and in rhythm with today's customers. Used even for live-culture products like yoghurt and probiotics, it is simply a smart package for smart and healthy products.



## ASEPTIC SOLUTIONS

When Tetra Brik was introduced as an aseptic version, it revolutionised the liquid food industry forever. Today, Tetra Brik Aseptic is the best-selling carton package range for liquid beverages in the world. It offers distribution and storage at ambient temperatures, without the need of additives or preservatives, whilst protecting the nutritional value of the packed product. At home or on-the-go, it is perfect in places where the chilled chain is limited. The brilliance of aseptic technology, and our relentless focus to add the latest advances in technology to Tetra Pak packaging lines, makes all this possible.



**SMART FOR THE PLANET.**



The simplicity of a Tetra Brik package is unconquered. Its ingenious design uses the smallest total amount of material possible for a functional, protective package, whilst maximising the amount of renewable material. It's full of product, nothing else. And when disposed of, it flattens completely. Transporting air is, of course, something nature and our customers can do without.

### **RENEWING. REDUCING. RECYCLING.**

A Tetra Brik package consists of approximately 75% material from a renewable resource – wood. The material comes from audited suppliers ensuring that all wood we use is traceable and legal. New trees are planted to replace the ones harvested, ensuring continuous forest growth. As you know, trees absorb CO<sub>2</sub> and produce oxygen, resulting in less global warming and better air quality. The high content of renewable material along with transportation efficiency gives Tetra Brik packages a low carbon footprint.

Tetra Pak also contributes to the reduction of carbon emissions by using green energy and targeting processes that we can make more efficient. Our goal is a 10% reduction of carbon emissions during the period 2005–2010 (as a part of the WWF Climate Savers initiative).



In the coming years, Tetra Pak will make substantial investments in our markets in order to improve environmental consumer awareness, collection & sorting systems as well as recycling capacity. In doing this, we ensure that even more of our packages end up in the recycling system. It's our responsibility to take constant actions to preserve our forests, use as little raw material as possible, contribute to the re-use of packages and take an active part in actions against global warming.

Smart for the planet and for coming generations.

# IN GOOD SHAPE!

Tetra Brik packaging comes in different basic formats: Base, Slim/Mid, Square and the new Edge. They all share the same smart common ground, but have evolved to fit the different demands of today's markets.



## TOUCH BASE

Tetra Brik Base is the original, blockbuster, brick-shaped package. This simplistic solution is ideal for commodities like milk, orange juice and tomatoes as well as on-the-go products. Smart, proven and as solid as a brick!



Sensory Straw for a lovely taste

## A SLIM FIT

Slim and Mid, the 2nd generation in this best-selling range, have a narrower front panel, more height and an even wider selection of openings and closures to choose from. Customers all over the globe are using these shapes to market their products with this slimmer look and feel. For a vast variety of products, they speak the international language of functionality and design.

## Tetra Brik® Edge™

About to be launched worldwide for chilled white milk and cultured milks.



Tetra Brik Edge. Large opening hole and slanted top for improved pourability.



## HIP TO BE SQUARE

Tetra Brik Square is growing fast, especially as a brand-owner's choice. And it's a smart choice. With an advanced re-sealable opening system, its standout, skyscraper image and all the other advantages you get when you choose Tetra Brik packaging, you can understand why.



## EVEN MORE ...EDGE

Tetra Brik Edge not only looks different, it stacks differently too. It's all to do with the position of the cap and the package's sloping top angle. The result? More liters to the roll container. And it's not just the look and distribution that gives this package "Edge". Tetra Brik Edge has been tested and approved by the Swedish Rheumatism Association proving that when it comes to handling, opening and pouring, it's a solution for everyone. Smart evolutions that keep the Tetra Brik range smart.



There are more than a  
thousand different ways  
to configure  
a Tetra Brik package.

OPEN! ▶





# THE RANGE

Choose shapes, volumes, opening alternatives, closures, packaging material and printing options. Sound complicated? It's not. The Tetra Brik and Tetra Brik Aseptic range has been fine-tuned for over 45 years. We still live by the motto - keep it simple.





Tetra Brik Aseptic **BASE**  
9 packages from 100 -1000 ml



Tetra Brik Aseptic **SQUARE**  
4 packages from 200 -1000 ml



Tetra Brik Aseptic **SLIM/MID**  
13 packages from 125 - 2000 ml

## ASEPTIC SOLUTIONS.

Tetra Brik Aseptic, our ambient solution, allows a wide variety of products to be filled and distributed around the world, at ambient temperatures. Doing this, we keep the product fresh and safe whilst contributing to lower energy consumption.

# OPEN MINDED.

Choose an opening that fits your product, budget and consumer behaviour. Flat PullTab openings or screw caps come in a vast variety of sizes, colours and designs.



Straw hole



PullTab



Perforation



SlimCap



StreamCap



SimplyTwist



SimplyTwist Maxi



SimplyTwist 34



SimplyPull



FlexiCap



ReCap3





#### **Milk flavouring straw**

Sip white milk and experience the infusion of great flavour or a probiotic ingredient. Feature and functionality, all in one. Kids love it. Unistraw, one of our trusted partners, offers the multi-award winning Sipahh milk flavouring straw in a specially designed, on-pack version, to our customers. Exclusively.



#### **U-Straw**

A real children's favourite. Easy to use and available in up to 6mm diameter for a high-flow drinking experience.



#### **Straight Straw**

The classic straight straw is available in almost any colour. Our lowest costing straw, it still has the same high quality tubing and hygienic wrapping. Compare us!

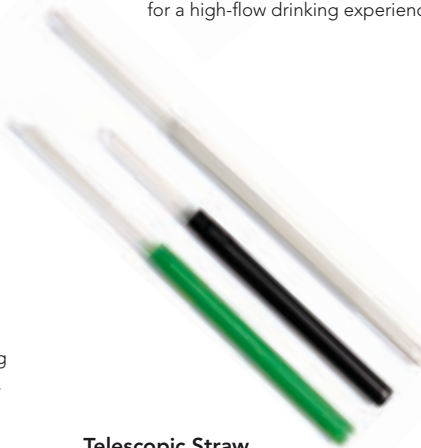

#### **Telescopic Straw**

A smart solution, providing a longer straw even on small portion packs.

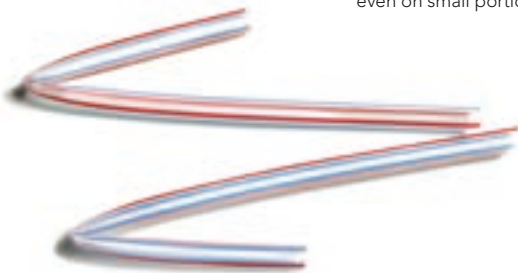

#### **Flip & Sip**

Flip open the straw – Have a sip. Close it.



#### **Sensory Straw**

The sensory straw delivers a brand new drinking experience. With the patented "flavour boost" system, it boosts the sensory experience of products, ranging from milk to wine. Feel the burst of flavour explode in your mouth!

## **STRAWS UNLIMITED.**

Straws don't just come in different colours and sizes, they also bring with them specific functionalities and features to improve the drinking experience. Looking for a biodegradable, colour changing, scented straw with a printed straw film? We can deliver. If we don't have it, we'll make it. Together.

# CHILLED SOLUTIONS.

Our chilled solutions are designed for products that are filled and distributed within a chilled chain. The name of this game is high quality. Our Tetra Brik range is a key player in this field.



Tetra Brik **BASE**  
4 packages from 200 - 1000 ml



Tetra Brik **SQUARE**  
4 packages from 500 - 1136 ml



Tetra Brik **SLIM/MID**  
2 packages: 100 & 200 ml



Tetra Brik **EDGE**  
1000 ml. Soon to be released worldwide

## A FAMILY FOR FAMILIES.

Tetra Brik and Tetra Brik Aseptic packages offer a wide range of formats and shapes to suit different products, different occasions and all kinds of people. Pick the package that suits your need.



## LOWER EMISSIONS

Ambient packaging, protecting what's good inside for a long period of time, is not just a convenience. When you can do without refrigeration, you save valuable energy and create lower emissions.



Once the carton is empty, it folds flat into almost nothing. You can fit lots of that in your recycling bin!



## THE SPACE SAVER.

Tetra Brik packaging material comes on a roll, making it very efficient to transport and store (40% less space than pre-cut carton blanks).

Straight from the roll we create the rectangular shape of the Tetra Brik package, geometrically the most efficient shape possible. All this, naturally, impacts heavily on costs of distribution throughout the value chain. Whether it's transportation, palletizing, stacking, storing, displaying or, finally, loading the shelves at home, there is no easier shape to work with.

In a way, it's the closest thing to not having a package at all.





## KEEP ROLLING!

A Tetra Brik package folds into shape, straight from the roll, and is filled with the liquid food of choice, fast and efficiently. It's a textbook case of lean production. The corners have already been cut, or in this case, folded.

No time spent on downtime, all time spent on value-adding production. Did someone mention economy?

Aseptic technology enables food to stay fresh for more than 6 months without the risk of contamination, loss of nutrition or changes to the taste of the product. The entire filling process is performed in a sterile environment, the packaging material is sterilised on both sides and the packages are sealed under the liquid level to avoid contamination. Add to that a distribution chain without the need for low temperatures, and you get a technology that is extremely efficient from an energy consumption perspective.

For the chilled business segment, our extended hygiene technology (XH) fills the product in a sterile, closed environment – the hygienic chamber – to achieve product purity, safety and prolonged shelf life. Combining this solution with state-of-the-art product processing solutions and a sound chilled distribution set-up, creates business opportunities that were unreachable a couple of years ago.

# THE POWER OF INTEGRATION

Complete production lines consist of, for example, filling machines, conveyors, cap applicators, secondary packaging equipment and pallet systems.

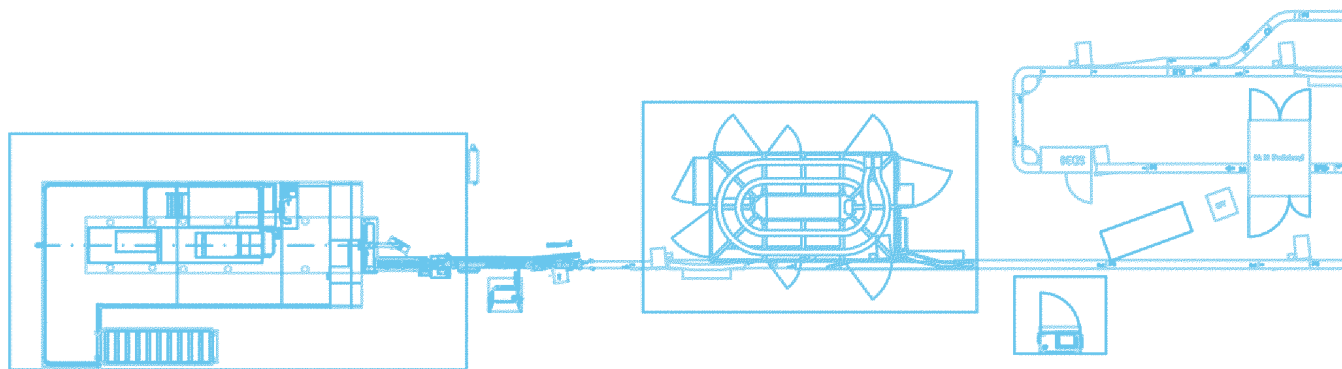

## FLEXIBILITY

With Volume Conversion Kits and QuickChange, our flexible lines provide investment protection and optimal capacity utilisation.

**Tetra Pak® A3/Flex** is our most flexible machine, handling 24 different TBA and TPA packages from 200-2000 ml. The QuickChange™ feature enables conversion between volumes with the same cross section, in just 10 minutes. Capacity: up to 8,000 p/h.

**Tetra Pak® C3/Flex** for chilled products, combines long production runs of mainstream products with low volume, value-added products. Range: 200-1136 ml. Capacity: up to 8,000 p/h.

**Tetra Pak® A3/CompactFlex** is designed to produce aseptic portion packages. It handles sizes from 100 ml to 330 ml in the Base, Slim/Mid and Square ranges. Capacity: up to 9,000 p/h.





## SPEED

Extremely low operational costs  
for high volume producers.

**Tetra Pak® A3/Speed** - a world first for capacity makes our experience in high speed carton packaging an unrivalled one. Capacity: up to 24,000 p/h for TBA portion packages and 15,000 p/h for TBA 1-litre packages.

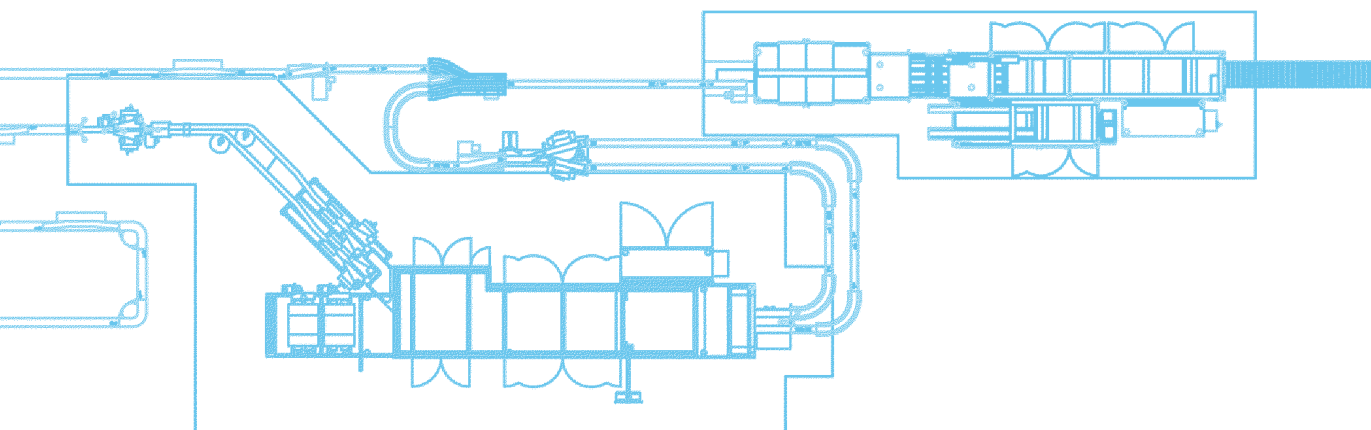

At Tetra Pak, we firmly believe in thinking in terms of line integration, to offer our customers smooth and efficient operations. Beginning at the drawing board, our engineers create integrated lines, using the latest in automation technology and line control systems. The results? All parts working in harmony and performing at their best. We call this concept iLine™.

Uptime robustness, mechanical efficiency and increased capacity are the direct benefits, all of which help lower operational costs. With more than 430 high speed lines already installed world-wide, our unrivalled experience as world leader in this technology makes us unique. When we deliver a specified line, you can also choose to have a performance agreement. This is a mutual agreement with our customers, where we guarantee a certain line-performance. This is a smart benefit, built on common sense.

The brand new Tetra Pak® A3/CompactFlex along with the new Tetra Pak® A3/Flex and the new Tetra Pak® A3/Speed are all part of the iLine™ concept, which is to be fully released during 2009.





## A SECOND THOUGHT

We offer a wide range of secondary packaging solutions, from convenient sales solutions to heavy-duty cardboard protection. All solutions can be robot palletised for high flexibility of pallet configurations. Our portfolio consists of Tetra Pak solutions along with selected solutions from third party suppliers, offering a wide range and ensuring efficient packaging lines.

## LET YOUR BRAND SHINE.

A Tetra Brik package gives you great billboard space and only your creativity limits what you can do to make your brand shine. Use imagery, copy and colour to promote your brand, selling your unique product and story. Be sure to make use of the billboard space at hand to stand out from the crowd. Want a bigger impression? Do it with secondary packaging solutions.

Having a free billboard, on-site, to promote your message makes sense. Having it on an ecologically sound package makes good sense.



FILM WRAPPED  
UNITS WITH  
CARD INSERTS



MULTIPACKS  
(WITH OR  
WITHOUT HANDLE)



WRAPAROUNDS



FILM WRAPPINGS

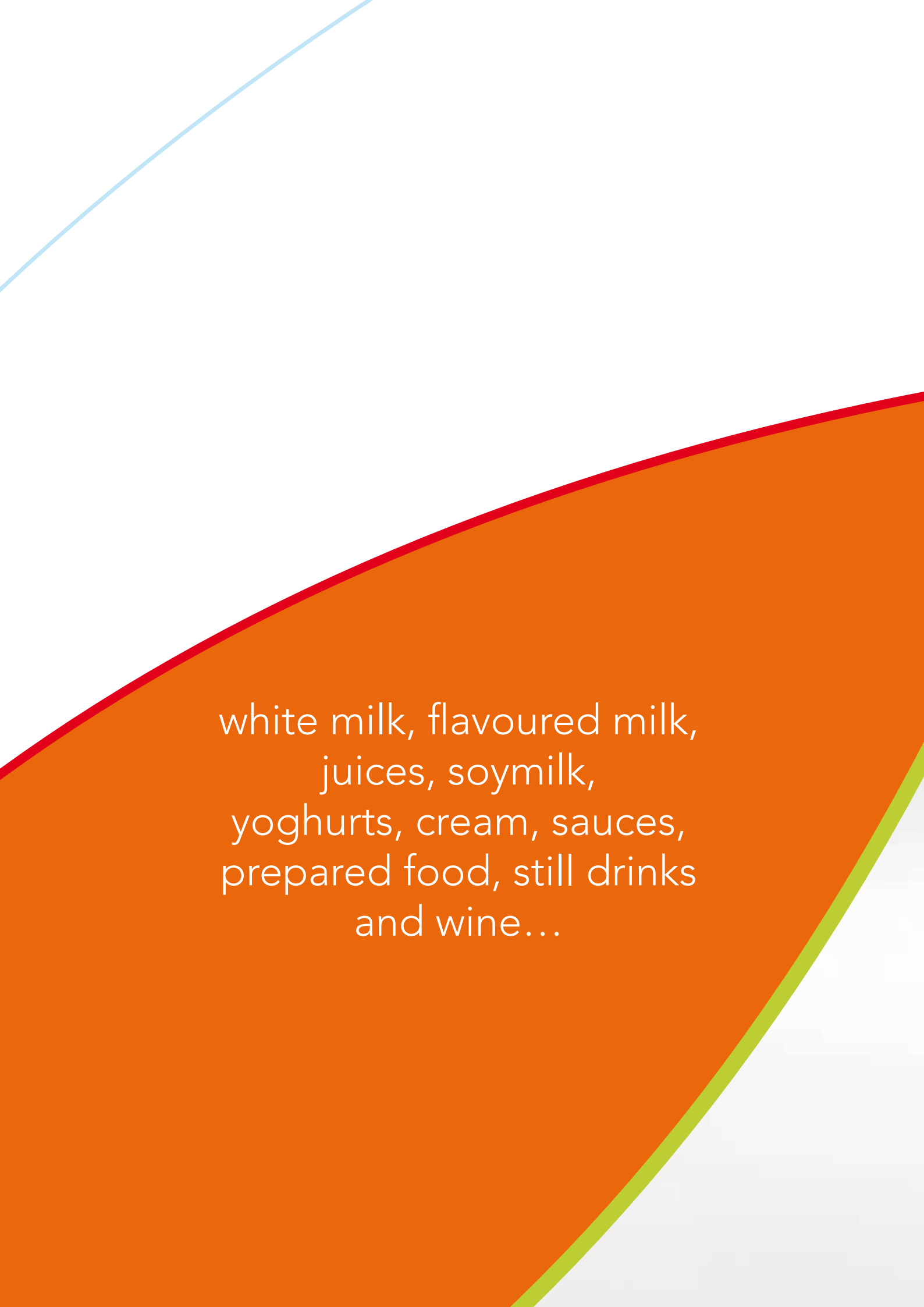

white milk, flavoured milk,  
juices, soymilk,  
yoghurts, cream, sauces,  
prepared food, still drinks  
and wine...

## WHAT'S SMART FOR YOU?

Tetra Brik and Tetra Brik Aseptic packages are designed to fit everyday needs. Their production, configuration and promotional qualities, along with a sound environmental profile, add up to this – whatever your market position and ambition, we can help you.





Tetra Pak not only provides packages and packaging equipment; we also provide complete systems integrating processing equipment, packaging machines, distribution equipment, software and maintenance. When it comes to designing and installing your equipment solutions, we have years of worldwide experience.

We will gladly pass our know-how and expertise, as a world leader in our field, on to you.