

Strong and Reliable

LKHP Centrifugal Pump for High Inlet Pressure

Application

The LKHP pump is a highly efficient and economical centrifugal pump, specially designed for high inlet pressures, i.e. for use in filtration systems. LKHP meets the requirements of sanitary and gentle product treatment and chemical resistance, and is available in nine sizes, LKHP-10, -15, -20, -25, -35, -40, -45, -50, -60.

Standard Design

The LKHP pump consists of a special motor, stub shaft, compression coupling, adaptor, back plate, impeller, impeller screw, pump casing and shaft seal. The LKHP pump is designed for CIP-cleaning with emphasis on large internal roundings and easily cleanable seals.

Shaft Seals

LKHP can be fitted with two types of mechanical seals:

- Single internal seal.
- Flushed seal.

Both seal types have stationary seal ring and rotating seal ring in silicon carbide. The secondary seal of the flushed seal is a long lasting lip seal.

Materials

Product wetted steel parts:	Acid-resistant steel AISI 316L.
Other steel parts:	Stainless steel AISI 304.
Product wetted seals:	EPDM rubber.
Finish:	Polished ≤ 32 Ra.

Technical Data

Max. inlet pressure:	580 PSI (40 bar).
Temperature range	14° F to 284° F (EPDM).
Water pressure:	14.5 PSI.
(Flushed seal)	
Water consumption:	0.06-0.12 GPM
(Flushed seal)	
Noise level (at 3 ft.):	60 - 80 dB (A).



LKHP.

Motor

Special NEMA C-Face motor, foot mounted motor according to NEMA standards at 3500 or 1750 RPM. Premium efficiency, TEFC, insulation Class F

Dimensions (in)

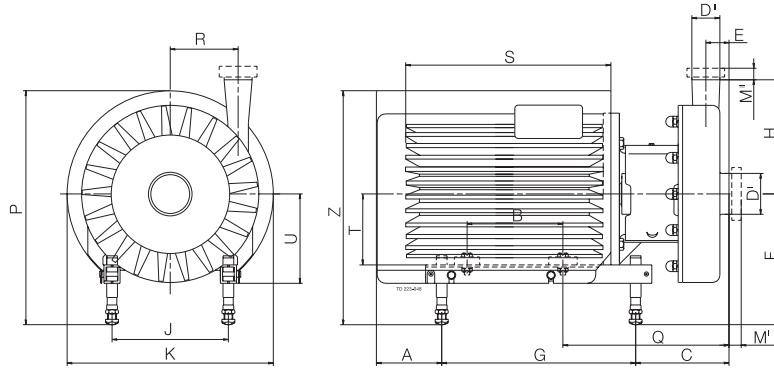

LKHP-10

Size	Motor			
	2 Hp	3 Hp	5 Hp	7.5 Hp
B	5.00	4.50	5.50	5.50
C	5.84	6.22	6.22	6.14
E	1.14	1.14	1.14	1.14
F minimum	6.00	7.00	7.00	7.75
F maximum	8.00	9.00	9.00	9.75
G	9.53	12.60	12.60	14.17
H	5.59	5.59	5.59	5.59
J	5.50	7.50	7.50	8.50
K	9.72	9.72	9.72	9.72
P minimum	10.86	11.86	11.86	12.61
P maximum	12.86	13.86	13.86	14.60
Q	9.07	9.96	9.96	11.45
R	3.43	3.34	3.43	3.43
S	10.67	11.00	12.00	14.55
U	3.81	5.81	5.81	6.56
Weight (lbs.)	111.00	131.00	148.00	199.00

LKHP-20

Size	Motor			
	3 Hp	5 Hp	7.5 Hp	10 Hp
B	4.50	5.50	5.50	7.00
C	6.77	6.77	6.70	6.70
E	1.38	1.38	1.38	1.38
F minimum	7.00	7.00	7.75	7.75
F maximum	9.00	9.00	9.75	9.75
G	12.60	12.60	14.17	14.17
H	7.09	7.09	7.09	7.09
J	7.50	7.50	8.50	8.50
K	9.96	9.96	9.96	9.96
P minimum	11.98	11.98	12.73	12.73
P maximum	13.98	13.98	14.73	14.73
Q	10.51	10.51	12.01	12.01
R	3.46	3.36	3.46	3.46
S	11.25	12.30	14.80	16.34
U	5.81	5.81	6.56	6.56
Weight (lbs.)	137.00	154.00	205.00	230.00

LKHP-40

Size	Motor				
	10 Hp	15 Hp	20 Hp	25 Hp	30Hp
B	7.00	8.25	10.00	9.50	11.00
C	6.70	7.76	7.76	8.27	8.27
E	1.30	1.30	1.30	1.30	1.30
F minimum	7.75	8.75	8.75	9.50	9.50
F maximum	9.75	10.75	10.75	11.50	11.50
G	14.17	19.02	19.02	20.00	20.00
H	8.35	8.35	8.35	8.35	8.35
J	8.50	10.00	10.00	11.00	11.00
K	12.95	12.95	12.95	12.95	12.95
P minimum	14.23	15.23	15.23	15.98	15.98
P maximum	16.23	17.23	17.23	17.98	17.98
Q	12.01	13.78	14.28	14.28	14.28
R	4.61	4.61	4.61	4.61	4.61
S	16.34	18.93	20.68	22.68	24.18
U	6.56	7.56	7.56	8.31	8.31
Weight (lbs.)	262.00	355.00	405.00	486.00	517.00

Dimensions (in)

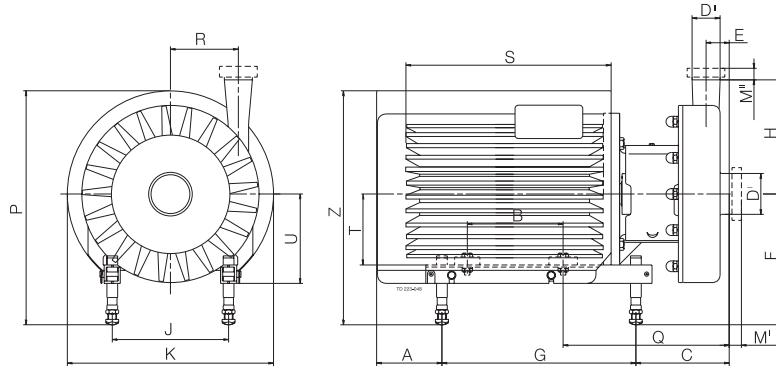

LKHP-50

Size	Motor					
	7.5 Hp	10 Hp	15 Hp	20 Hp	25Hp	30Hp
B	5.50	7.00	8.25	10.00	9.50	11.00
C	12.48	12.48	12.91	12.91	14.83	14.83
E	1.61	1.61	1.61	1.61	1.61	1.61
F minimum	7.75	7.75	8.75	8.75	9.50	9.50
F maximum	9.75	9.75	10.75	10.75	11.50	11.50
G	14.17	14.17	19.02	19.02	20.00	20.00
H	8.07	8.07	8.07	8.07	8.07	8.07
J	8.50	8.50	10.00	10.00	11.00	11.00
K	12.95	12.95	12.95	12.95	12.95	12.95
P minimum	14.23	14.23	15.23	15.23	15.98	15.98
P maximum	16.23	16.23	17.23	17.23	17.98	17.98
Q	17.79	17.79	20.35	20.35	20.84	20.84
R	4.61	4.61	4.61	4.61	4.61	4.61
S	14.80	16.34	18.93	20.68	22.68	24.18
U	6.56	6.56	7.56	7.56	8.31	8.31
Weight (lbs.)	241.00	266.00	359.00	409.00	590.00	521.00

LKHP-60

Size	Motor					
	7.5 Hp	10 Hp	15 Hp	20 Hp	25Hp	30Hp
B	5.50	7.00	8.25	10.00	9.50	11.00
C	12.56	12.56	12.99	12.99	14.91	14.91
E	1.65	1.65	1.65	1.65	1.65	1.65
F minimum	7.75	7.75	8.75	8.75	9.50	9.50
F maximum	9.75	9.75	10.75	10.75	11.50	11.50
G	14.17	14.17	19.02	19.02	20.00	20.00
H	10.28	10.28	10.28	10.28	10.28	10.28
J	8.50	8.50	10.00	10.00	11.00	11.00
K	12.95	12.95	12.95	12.95	12.95	12.95
P minimum	14.23	14.23	15.23	15.23	15.98	15.98
P maximum	16.23	16.23	17.23	17.23	17.95	17.98
Q	17.87	17.87	20.42	20.42	20.92	20.92
R	4.02	4.02	4.02	4.02	4.02	4.02
S	14.80	16.34	18.93	20.68	22.68	24.18
U	6.56	6.56	7.56	7.56	8.31	8.31
Weight (lbs.)	251.00	276.00	369.00	419.00	500.00	531.00

Volumetric flow
H (ft)

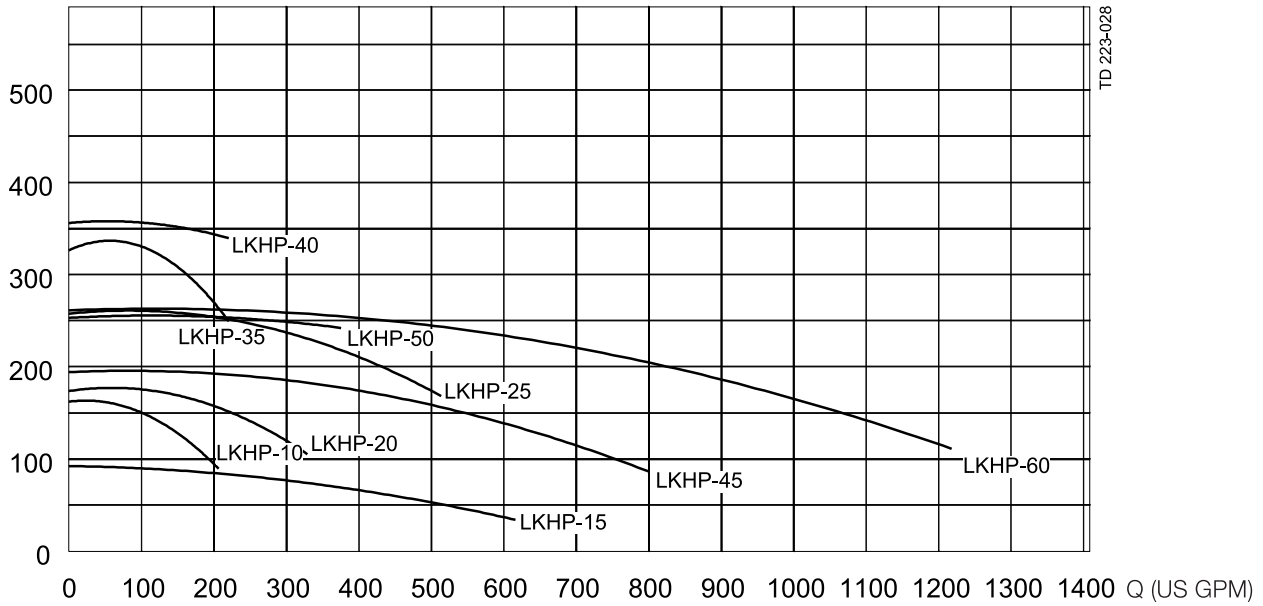

Connections (in)

LKHP-10, LKHP-20, LKHP-35

D 1/2.50	Tri-Clamp®
D 2.50	
M ^I	1.12
M ^{II}	1.12

LKHP-25

D 3.00	Tri-Clamp®
D 2.50	
M ^I	1.12
M ^{II}	1.12

LKHP-40

D 3.00	Tri-Clamp®
D 2.50	
M ^I	1.12
M ^{II}	1.12

LKHP-15, LKHP-45, LKHP-50

D 4.00	Tri-Clamp®
D 3.00	
M ^I	1.12
M ^{II}	1.12

LKHP-60

D 4.00	Tri-Clamp®
D 4.00	
M ^I	1.12
M ^{II}	1.12

Options Equipment

- Impeller with reduced diameter.
- Motor for other voltage and/or frequency.
- XP motors.
- Flushed shaft seal.

Material grades

- Surface roughness, product wetted parts: unpolished, 32Ra, micro inches (0.8 mm), or higher finishes.
- Seals in Nitrile (NBR) or Fluorinated rubber (FPM).

Ordering

Please state the following when ordering:

- Pump size.
- Connections.
- Impeller diameter.
- Motor size.
- Single or flushed shaft seal.
- Optional extras.

Note!

The curves for LKHP are the same as those for LKH.