

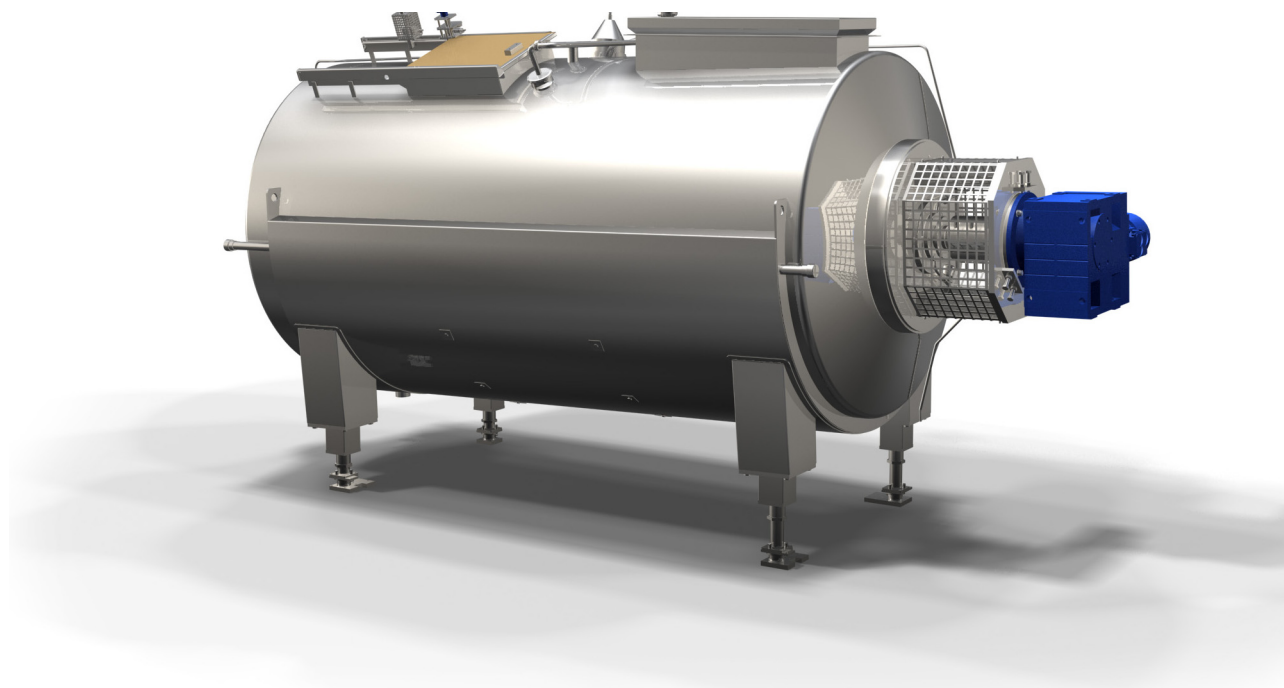

## Tetra Damrow™ Blender

Blending of cottage cheese curd



### Highlights

- Gentle mixing of cottage cheese curd with cream/dressing
- Consistent curd/cream ratio during emptying
- Provided with double jacket for cooling

### Application

The Tetra Damrow Blender unit is specially designed to ensure a gentle and efficient blending of curd and cream/dressing and other additives. The Tetra Damrow Blender unit can be fitted with a weighing system to achieve high accuracy in the curd-dressing ratio.

### Working principle

The Tetra Damrow Blender unit is filled with part of the cream/dressing to prevent curd damage during filling. The specially designed agitator ensures a gentle and efficient blending of curd and cream/dressing.

When all the curd has been transferred the remaining amount of cream/dressing is dosed.

The required blending time is typically 30 minutes before the product can be transferred to the filling machine.

## Material

Standard: Stainless steel AISI 304

Optional: Stainless steel AISI 316

## Technical data

Control system: Stand alone (optional)  
Standard capacity: 7,500 lbs and 12,500 lbs  
of final product

## Connections

Curd inlet:  $\varnothing 1' 8''$  (manway)  
Cottage cheese outlet: 4"  
Ice water in: 2 pcs. 1½"  
Ice water out: 3"  
CIP inlet: 2½"  
Drive: 230/460 V, 60 Hz

## Options

- Automation system, fully integrated in the line control system
- Load cells, integrated in control system

The Tetra Damrow Blender unit is just one item in our portfolio of cottage cheese making equipment incorporating the latest engineering standards and cottage cheese making technology.

Our sales and engineering staff will work closely with you to design the optimum solution to meet all your needs.

Tetra Pak Cheese and Powder Systems offers complete in-house design, engineering, fabrication, installation and commissioning.

## Capacities, availability, dimensions and consumptions

Type	Length	Width	Height	Weight (lbs)	Ice water (GPM)	CIP (GPM at 29 PSI)	Electric power (hp)
7,500 lbs	11' 2"	5' 9"	8' 6"	3,000	35	110	5.4
12,500 lbs	15' 7"	5' 9"	8' 6"	3,300	66	110	5.4

## Dimensions

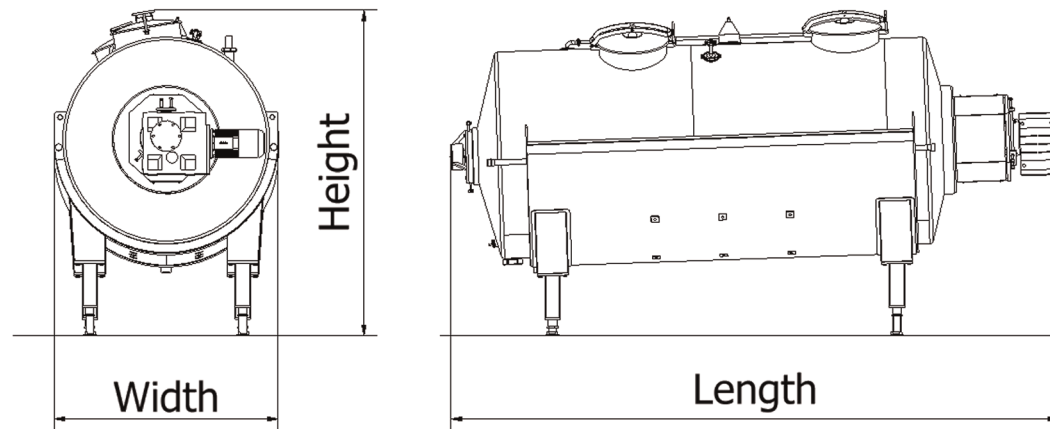

## The Tetra Pak Cottage Cheese Line consists of the following equipment:

- Tetra Scherping Horizontal Cottage Cheese Vat used for curd production
- Tetra Damrow Enclosed Cottage Cheese Vat used for curd production
- Tetra Damrow Drainer Washer used for whey draining, washing and cooling of curd
- Tetra Damrow Drum Drainer used for draining of washing and cooling water. The Tetra Damrow Drum Drainer unit needs to be combined with a blender. One Tetra Damrow Drum Drainer can serve several blenders
- Tetra Damrow Blender used for blending of curd and dressing
- Tetra Damrow Drainer Blender used for draining of washing and cooling water and for blending of curd and dressing

We reserve the right to introduce design modifications without prior notice. Tetra Pak, , PROTECTS WHAT'S GOOD, Tetra Scherping and Tetra Damrow are trademarks belonging to the Tetra Pak Group.

www.tetrapak.com

 Tetra Pak