



Tetra Pak® Decoration Depositing Unit



Application

Tetra Pak® Decoration Depositing unit is an advanced, highly automated decoration solution used to produce exciting ice cream products on an extrusion line. It can decorate with chocolate compounds, jam or caramel. The system is very precise and allows a fast changeover between different designs.

The decoration process utilises depositing technology, where droplets create the desired patterns on moving products.

Highlights

- Easy to create new, exciting products
- Precise depositing of design on ice cream product
- Enhanced design flexibility with the flavour combination
- Lower operational cost
- No product, no print – ensured by sensor

Working principle

The Tetra Pak® Decoration Depositing unit consists of a pump system, depositing heads on a suspension and a design software.

The pump system supplies the depositing heads with decoration material at the right temperature and pressure. The tank's water jacket enables temperature control of the decoration material. A servo-controlled, non-pulsating pump recirculates the decoration material over the depositing heads, thereby creating a steady pressure. The tank has a filter to avoid clogging.

The depositing heads are placed in a suspension above the trays, one depositing head per product lane. Each depositing head has a 48-hole nozzle plate, covering the printing area so droplets can be deposited in the desired pattern. Adding chocolate compound, jam or caramel to the ice cream enables new, exciting taste combinations and designs.

The design patterns are created in the Design Studio software and uploaded to the depositing heads.

Printing, pattern selection, pressure setup and temperature control are managed from the screen interface (the HMI). The depositing heads can store a numerous amount of decoration patterns.

Basic unit

Tetra Pak® Decoration Depositing unit is a compact unit that provides a flexible solution for decorating ice cream products on trays. The pump system is positioned next to the worktable. Depositng heads are placed in a fixed position above the trays.

From the pump system the decoration material is supplied to the depositing heads through heated tubes.

When the depositing heads are not in use, they are placed in a docking position on the pump system. Here, it is also possible to store a spare depositing head, which stays heated and ready to use.

Nozzles can be delivered with different hole sizes depending on the decoration material and desired pattern.

The decoration material should be homogenous, with a maximum particle size of 50% of the nozzle hole diameter.

The entire liquid foodstuff circuit is CIP-able without the need for disassembly.

Layout

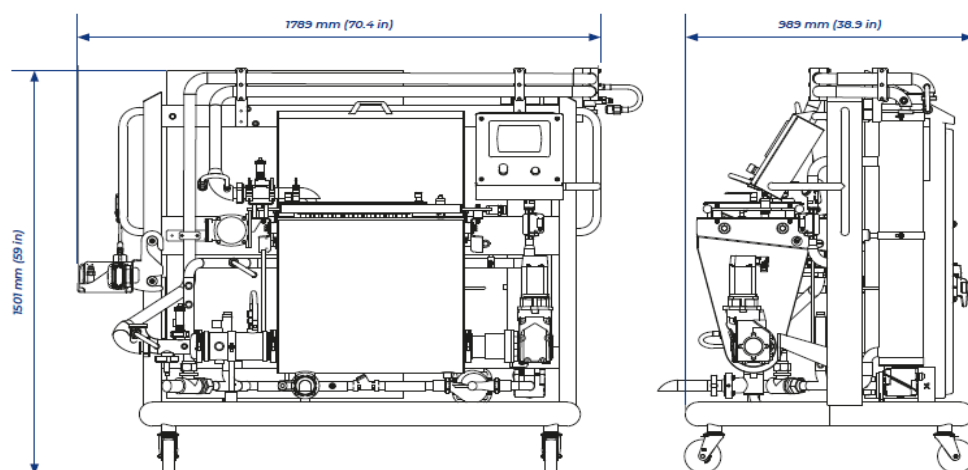

Measurements in mm (inches)

Main components

- Water jacketed holding tank, 70 litres
- Heat control system for $\leq 60 \pm 1$
- Temperature transmitters
- Level control
- Positive replacement servo pump for circulation of decoration material
- Filter system
- Depositng heads
- One size nozzle carrier
- 2x Water jacketed hoses
- Docking station for depositing heads
- Suspension of depositing head on worktable
- License for FoodJet Design studio software

Pre-test of pattern designs and decoration material in PDC including training in FoodJet Design studio software

Optional

- Spare depositing heads
- Extra nozzle plates with different hole size
- Tetra Pak to create the pattern designs with customer's input

Capacity

Capacity in line with Tetra Pak Extrusion lines.