



Food supplement and nutrition

Designed for success

 **Tetra Pak**[®]
PROTECTS WHAT'S GOOD

A woman with dark hair, wearing a grey sweater, is shown in profile, looking at a carton of 'wome daily' protein milk. She is holding the carton with her right hand. The carton is yellow and pink, featuring the brand name 'wome daily' in a stylized font. The background shows a grocery store aisle with shelves of similar products.

What makes a great package design?

Look at it! How proudly it expresses itself on the shelf, catching the eyes of exactly the right consumers, conveying your brand and your values. A dream package for your product. But – there's much more to it than just good looks.

Only good angles

All our packages are designed to stand out, whether on shelves, in gym refrigerators and cafés or online. However, the unique eight-sided shape of Tetra Prisma® Aseptic creates opportunities for even more stunning designs, telling your brand story regardless of which angle the consumer looks at it from. Let's make the corner panels pop!



First impressions last

Even if it is the inside that counts, the look can definitely make or break the first impression of your product. It's the 8-second moment of truth: the critical first seconds when your consumers notice the product's colour, shape and shelf display from a distance. Make your brand shine with metallic or holographic packaging material effects, or convey a more natural feeling with a matte paperboard look. But beware of too many details. The brain prefers clean, uncluttered designs.*

*Source: <https://www.tetrapak.com/insights/cases-articles/distinctive-by-design>



Are you shiny?



Are you matte?



Same product, different looks

How about a wall of... you?
With custom printing* you can create a massive billboard

effect on the shelf – or make unique packages for different target audiences. It fits well with the personalisation trend, where consumers are looking to find exact the right food supplement and nutrition products for their unique needs and taste preferences.



*US only, more regions to follow.

Great hold and pour

Consumers often drink directly from on-the-go packages, so a design that fits all hand sizes and provides optimum beverage flow control, is crucial for a spill-free experience. The ergonomic design and slanted top of Tetra Prisma[®] Aseptic, combined with the DreamCap[™] 26 or DreamCap[™] 26 Pro opening, make it a pleasure to drink from, reclose, and drop in a bag.

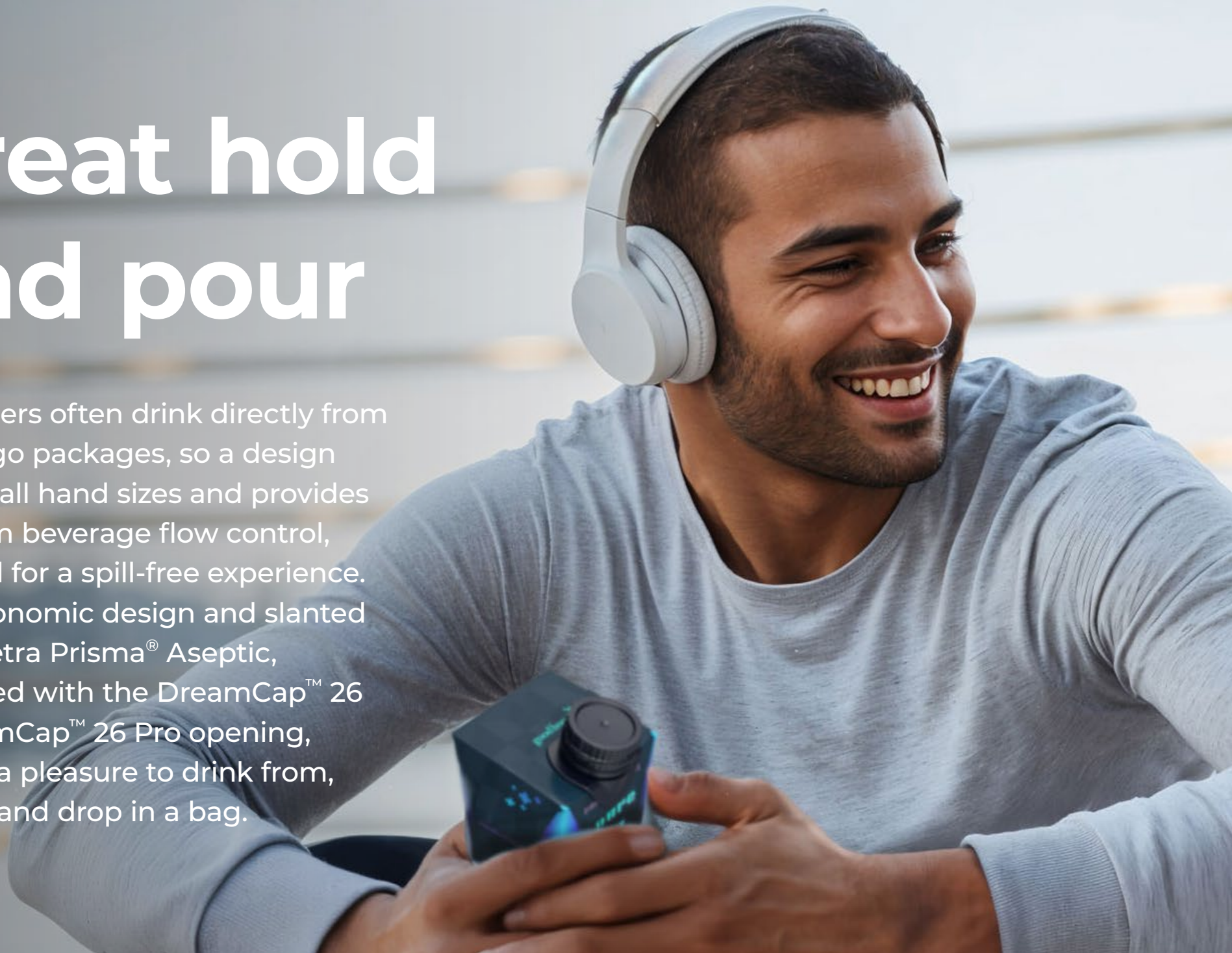

Safe to open and reclose

A resealable cap is key for on-the-go packages, which are often stored in bags together with other valuable things. Caps for on-the-go packages differ from caps for family-sized packs and are specifically designed for a comfortable yet controlled drinking experience.

Comfortable opening torque

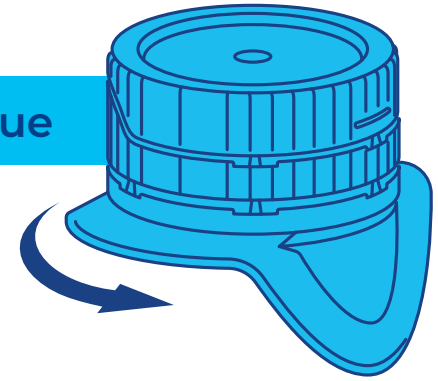

Tethered resealable cap

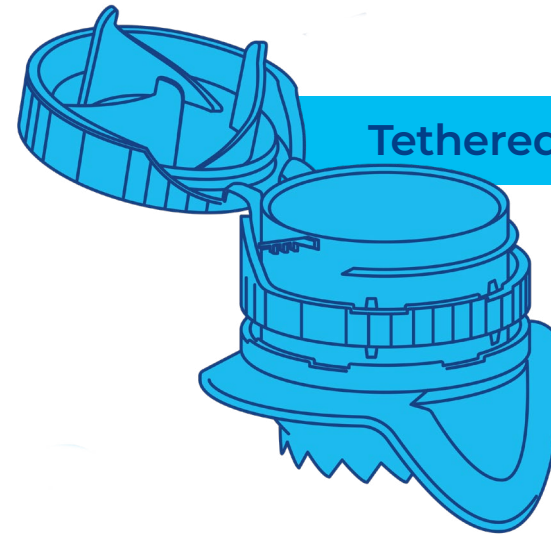

Visible tamper evidence ring

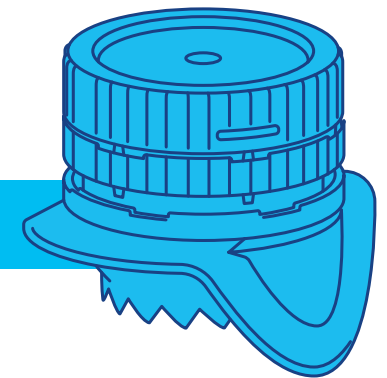

Stays fresh in a bag

Aseptic packages are perfect on-the-go, as consumers can carry them in their bags without worrying about the product going bad. Aseptic technology preserves the taste, appearance, textures and product quality of your beverage for an extended period of time without the need for preservatives or refrigeration. And these packages are easy to shake, ensuring the product is well-blended when it's time to drink.



**Well-protected,
without preservatives**

Keeps the contents safe

Food supplement and nutrition products have complex formulas and are therefore sensitive to external influences. Our packaging material protects the contents from degrading in sunlight. Correct dosing is also crucial, especially in special dietary and medical nutrition products. Ready-to-drink products ensure the right dose every time, conveniently and without mess.



**Protects contents
from sunlight**



Conveys sustainability values

Our cartons are made of, on average, 70% responsibly sourced paper, which is a renewable resource. All paper-board used in our packages comes from forests that are certified by the Forest Stewardship Council™ (FSC™) or other controlled sources.



70%
responsibly
sourced
paper

Efficient transportation and storage



No refrigeration needed

Aseptic technology allows for highly efficient, cost-effective transport chains as well as the possibility to reach consumers in more remote locations. But that's not all. Our packages are shaped to have small footprints, which makes them efficient to stack on pallets, and consequently in trucks.



Made for recycling

Our carton packages can be recycled where the right infrastructure is already in place. This means that the materials used for the package can be reused and upcycled into new products, contributing to a more circular economy*. To improve collection, sorting and recycling, we are continuously collaborating with stakeholders across the recycling value chain.

* <https://www.tetrapak.com/campaigns/go-nature-go-carton/explore/recycle-cartons>

Use,
reuse
& upcycle



Designed for success

Get in touch with us today!

First impressions last

Made for recycling

Stays fresh in a bag

Only good angles



Safe to open and reclose

Towards less fossil-based plastics

Conveys sustainability values

Keeps the contents safe

Great hold and pour

