

TETRA PAK® HIGH SHEAR MIXER

B200-500VAA, B300-1500VAA, B400-2500VAA

For beans and vegetable spreads



APPLICATION

This range of Tetra Pak® High Shear Mixers B200-500VAA, B300-1500VAA and B400-2500VAA for beans and vegetable spreads is the best solution for mixing products in this category. Designed to give the quality our most demanding customers want as well as being cost-efficient by utilizing the ingredients to the fullest. Cooking, grinding, mixing and cooling all in one mixer leads to fast batch times and enhanced flexibility.

The heating/cooling options in combination with the dynamic HS mixing head and double-shaft agitator make it possible to produce an almost limitless variety of different beans and vegetable-based products such as:

- refried beans
- hummus
- pesto
- vegetable spreads
- and more.

It allows you to produce a mix of any desired quality, whether it needs to be coarse, smooth or whether particles such as pieces of vegetables or herbs have to be blended in. This mixer is designed to give the optimal mixing result over and over again.

HIGHLIGHTS

- Double-shaft agitator.
- Patented dynamic HS mixing head – for variable shear, ideal when dealing with shear-sensitive ingredients or applications. Mix or gently blend all in the same unit.
- Easy process scale-up and precise replication of product quality.
- High level of flexibility to produce the widest range of products.
- Fast ingredient intake, based on vacuum, for both oil and powders.
- Sanitary execution due to large manway and bin lifter.
- Rapid mixing, high capacity and using ingredients to the fullest leads to optimal production costs.

WORKING PRINCIPLE

The Tetra Pak® High Shear Mixers B200-500VAA, B300-1500VAA and B400-2500VAA for beans and vegetable spreads are designed for a batch production set-up.

Variable shear, high shear mixing or gentle blending are all possible within the same unit, with our patented dynamic HS mixing head. Variable shear is ideal when dealing with shear-sensitive ingredients or applications. Additionally this gives a high level of control over quality parameters such as droplet size, product texture, appearance, taste and mouthfeel.

Intake of both liquid and powder ingredients into the mixing vessel (not directly into the HS mixing head) creates a pre-blend and eliminates the need for a pre-mixing process. There is an ergonomic execution for adding ingredients with a bin lifter and large manway. An automatic opening lid on the top and a bin lift system allow you to introduce larger ingredients in an efficient sanitary way, and the double-shaft agitator ensures that the product flows correctly around the tank, for an even distribution of the particles. A cooling/heating jacket enables you to heat up or cool down your product.

A fully automatic CIP system ensures fast and low-cost cleaning via strategically placed spray balls.

BASIC UNIT

- Dynamic HS mixing head with CIP cleaning behind primary seals
- Double-shaft agitator
- Vacuum system for ingredient introduction
- Heating and cooling jacket (500VAA)
- Direct steam injection (500VAA)
- Manway
- Direct liquid inlet
- CIP cleaning system
- Control system with Allen Bradley PLC and HMI

OPTIONS

- Outlet pump
- Bin lift system (stationary or non-stationary)
- Vibrating powder hopper
- Pressure vessel
- Jacket heating/cooling
- Direct steam injection

MATERIALS

- All components that come into contact with the food product are made from stainless steel AISI 316L.
- Other parts are made from AISI 304.
- All elastomers are FDA approved and EPDM and VITON compliant.



TECHNICAL DATA

Supply and consumption data

	B200-500VAA	B300-1500VAA	B400-2500VAA
Production setup	Batch	Batch	Batch
Voltage, V (Hz)	380-480 (50/60)	380-480 (50/60)	380-480 (50/60)
Power consumption, kW	52	80	120
Service water, l/h	100	200	250
Compressed air, NI/h	100	150	200
Cooling water, l/h	5 000	10 000	15 000
Steam, kg/h	500	750	1 000

Processing parameters

Capacity, kg/h	3 000	6 400	10 000
Capacity, No. of batches/h	6	4.3	4.8

LAYOUT

B200 500 VAA

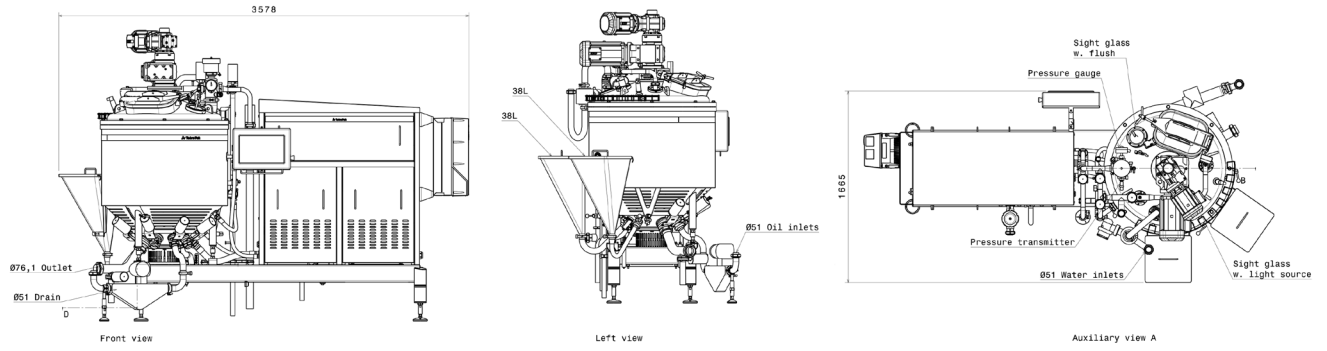

B300 1500 VAA

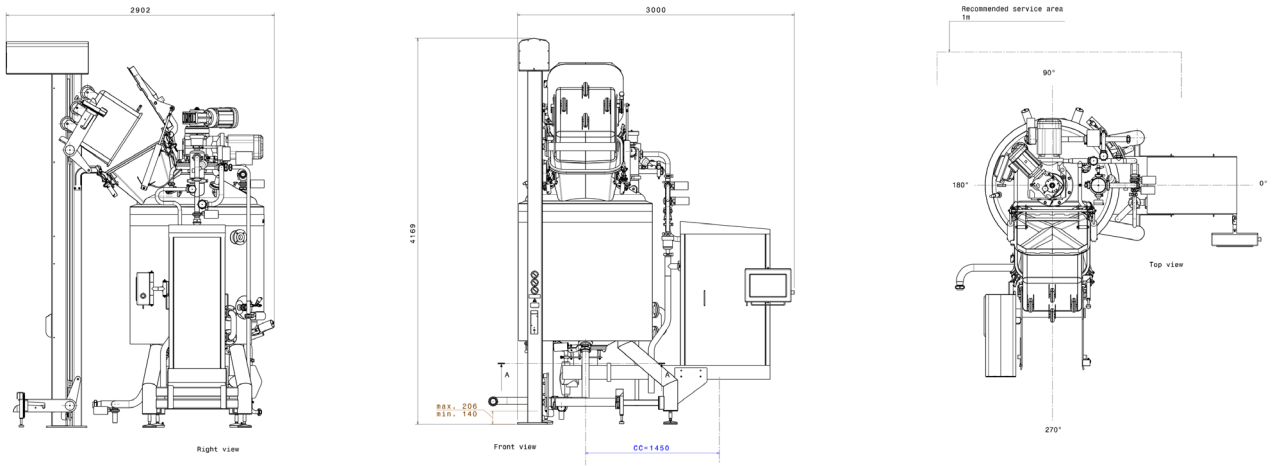

B400 2500 VAA

